

Power is our commodity, the world is our market !

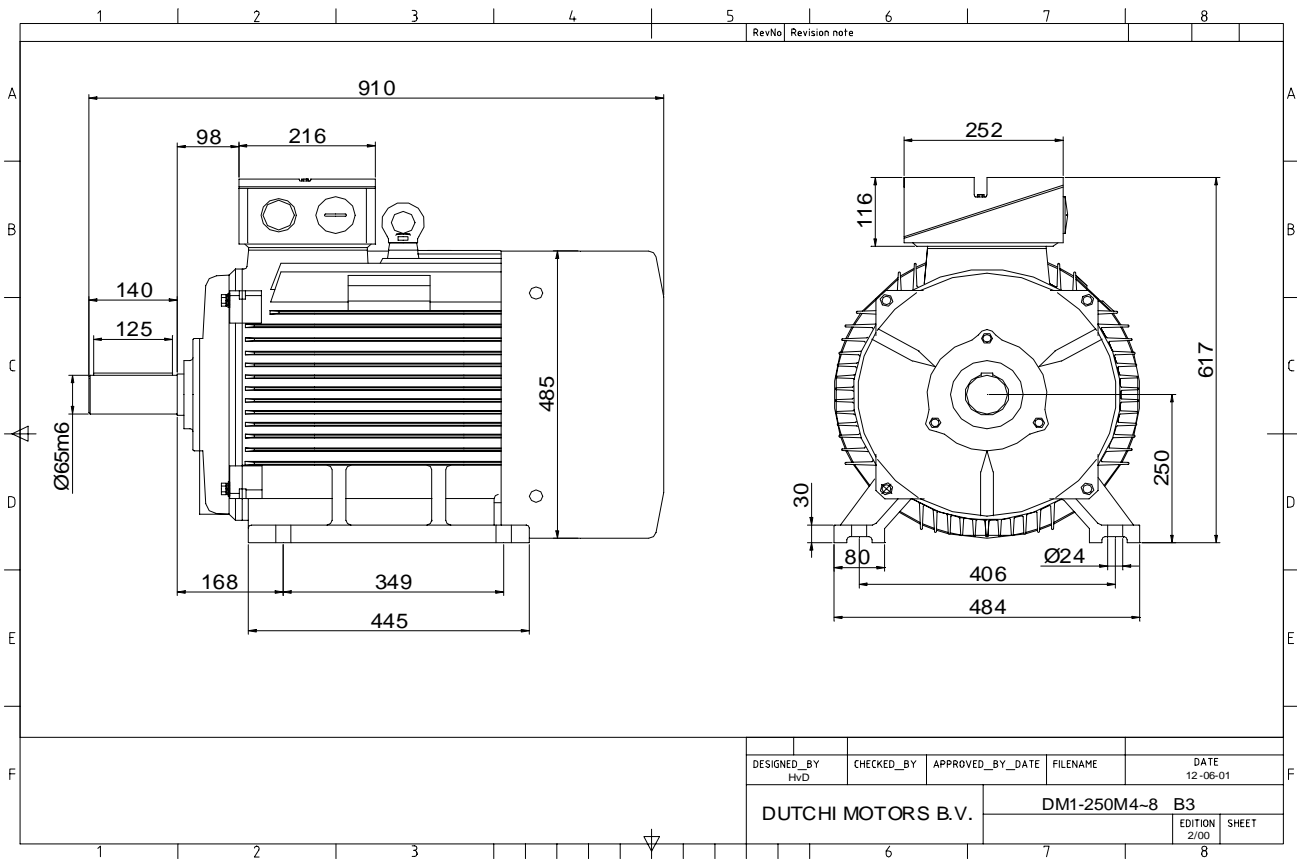

Specification **IEC 60034-1**  
 Manufacturer **Dutchi Motors B.V.**  
 Motor type **DM1- 250 M6**  
 Rated power **37** kW **S1** duty  
 Speed **980** r.p.m  
 Voltage **400 / 690** V  
 Frequency **50** Hz  
 Connection **Δ / Y**  
 Amps full load **66,0 / 38,1** A  
 Amps no-load(400V) **21,80** A  
 Enclosure **IP 55**  
 Insulation Class **F (temp. rise B (80 K))**

Max. coolant temp. **40°C**  
 Max. altitude **1.000** mtr, above sea level  
 Comment **3 x PTC 150°C**  
 Cable entries **2 x M63x1,5 + 1 x M20x1,5 (ptc)**

Feature **Cast-iron motor**  
 Weight **408** kg  
 Catalog no. **11136A37D**  
 Warranty **12~18 months**

Efficiency class **N/A**  
 Load data 100% 75% 50% 25%  
 Efficiency **91,6 91,7 90,7 85,8** %  
 Power factor **0,88 0,85 0,78 0,59**

Sound pressure level (1m) **63,9** dB(A)  
 Resistance R20 (open) **0,211** Ω  
 Resistance R20 **Δ 0,140** Ω

Full load torque **360,56** Nm  
 DOL Starting torque vs FL torque **1,94**  
 DOL Pull up torque vs FL torque **1,47**  
 DOL Pull out torque vs FL torque **3,09**  
 Star-Delta Starting torque vs FL torque **0,61**  
 Star-Delta Pull up torque vs FL torque **0,46**  
 Star-Delta Pull out torque vs FL torque **0,96**  
 DOL Starting current vs FL current **6,88**  
 Star Delta Starting current vs FL current **2,15**  
 Rotor Inertia **0,8070** kgm2

Bearing DE **6314 - ZZ C3**  
 Bearing NDE **6314 - ZZ C3**

WI	Change	date	sign.
<b>Dutchi Motors B.V.</b> P.O. Box 5390 NL-6802 EJ ARNHEM Tel : +31-(0)26 - 3541 600 Fax : +31-(0)26 - 3541 650		Discription Drawing made by : 27-04-04	date sign. Hvd
dutchi.motors@dutchi.nl www.dutchi.com			

Power is our commodity, the world is our market !

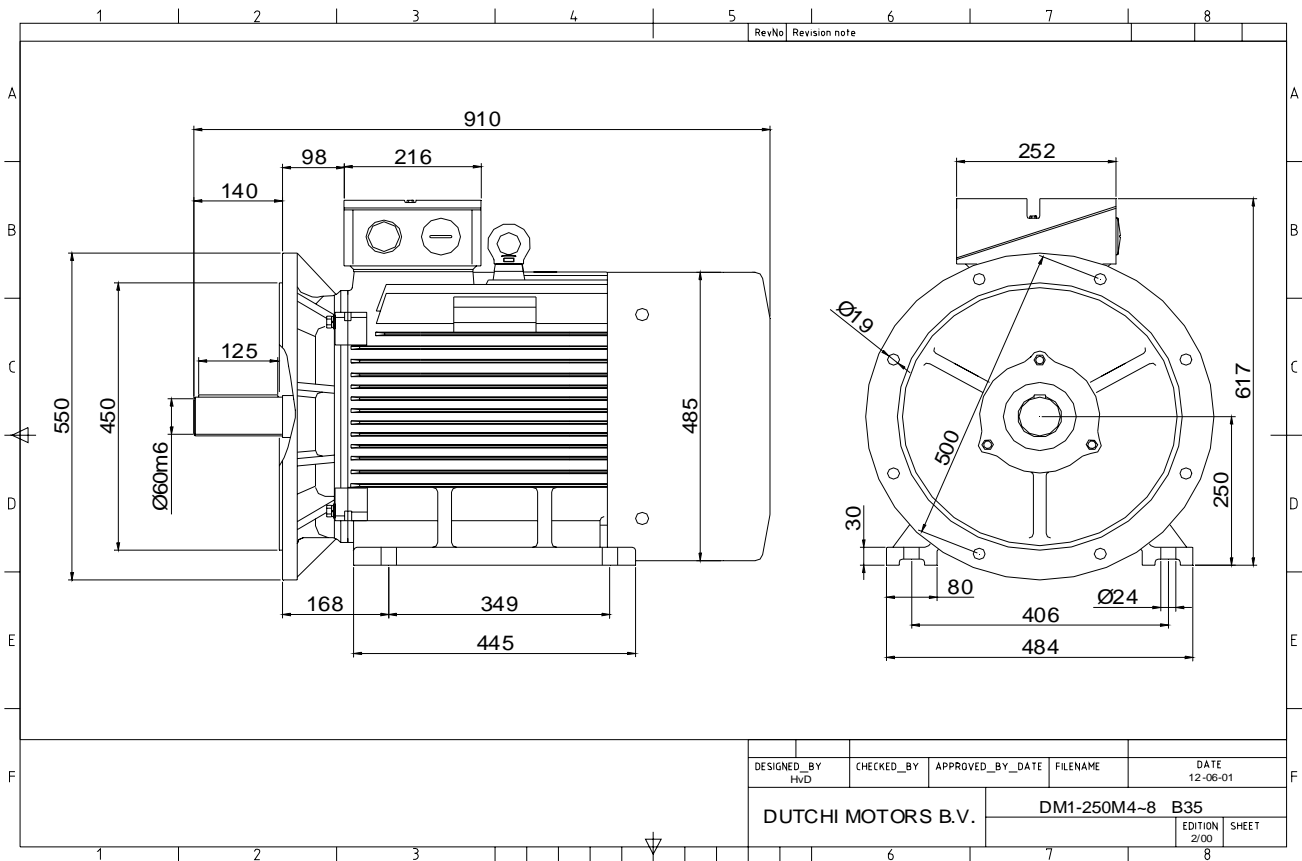

Specification **IEC 60034-1**  
 Manufacturer **Dutchi Motors B.V.**  
 Motor type **DM1- 250 M6**  
 Rated power **37** kW **S1** duty  
 Speed **980** r.p.m  
 Voltage **400** / **690** V  
 Frequency **50** Hz  
 Connection **Δ** / **Y**  
 Amps full load **66,0** / **38,1** A  
 Amps no-load(400V) **21,80** A  
 Enclosure **IP 55**  
 Insulation Class **F (temp. rise B (80 K))**

Max. coolant temp. **40°C**  
 Max. altitude **1.000** mtr, above sea level  
 Comment **3 x PTC 150°C**  
 Cable entries **2 x M63x1,5 + 1 x M20x1,5 (ptc)**

Feature **Cast-iron motor**  
 Weight **408** kg  
 Catalog no. **11536A37D**  
 Warranty **12~18 months**

Efficiency class **N/A**  
 Load data 100% 75% 50% 25%  
 Efficiency **91,6 91,7 90,7 85,8** %  
 Power factor **0,88 0,85 0,78 0,59**

Sound pressure level (1m) **63,9** dB(A)  
 Resistance R20 (open) **0,211** Ω  
 Resistance R20 **Δ 0,140** Ω

Full load torque **360,56** Nm  
 DOL Starting torque vs FL torque **1,94**  
 DOL Pull up torque vs FL torque **1,47**  
 DOL Pull out torque vs FL torque **3,09**  
 Star-Delta Starting torque vs FL torque **0,61**  
 Star-Delta Pull up torque vs FL torque **0,46**  
 Star-Delta Pull out torque vs FL torque **0,96**  
 DOL Starting current vs FL current **6,88**  
 Star Delta Starting current vs FL current **2,15**  
 Rotor Inertia **0,8070** kgm<sup>2</sup>

Bearing DE **6314 - ZZ C3**  
 Bearing NDE **6314 - ZZ C3**

WI	Change	date	sign.
Dutchi Motors B.V.		Description	date
P.O. Box 5390		Drawing made by :	27-04-04
NL-6802 EJ ARNHEM			
Tel : +31-(0)26 - 3541 600		dutchi.motors@dutchi.nl	
Fax : +31-(0)26 - 3541 650		www.dutchi.com	

Power is our commodity, the world is our market !

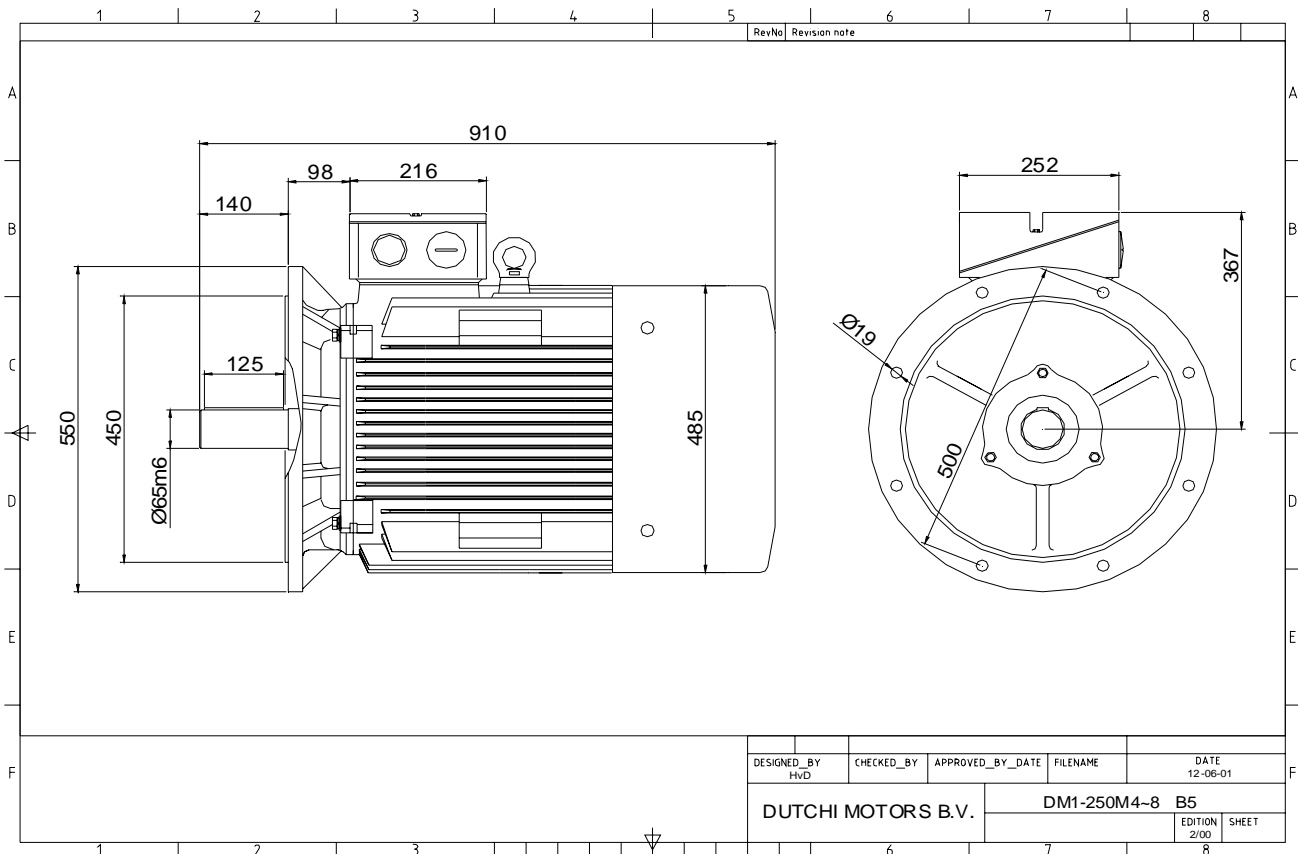

Specification **IEC 60034-1**  
 Manufacturer **Dutchi Motors B.V.**  
 Motor type **DM1- 250 M6**  
 Rated power **37** kW **S1** duty  
 Speed **980** r.p.m  
 Voltage **400 / 690** V  
 Frequency **50** Hz  
 Connection **Δ / Y**  
 Amps full load **66,0 / 38,1** A  
 Amps no-load(400V) **21,80** A  
 Enclosure **IP 55**  
 Insulation Class **F (temp. rise B (80 K))**

Max. coolant temp. **40°C**  
 Max. altitude **1.000** mtr, above sea level  
 Comment **3 x PTC 150°C**  
 Cable entries **2 x M63x1,5 + 1 x M20x1,5 (ptc)**

Feature **Cast-iron motor**  
 Weight **408** kg  
 Catalog no. **11236A37D**  
 Warranty **12~18 months**

Efficiency class **N/A**  
 Load data 100% 75% 50% 25%  
 Efficiency **91,6 91,7 90,7 85,8** %  
 Power factor **0,88 0,85 0,78 0,59**

Sound pressure level (1m) **63,9** dB(A)  
 Resistance R20 (open) **0,211** Ω  
 Resistance R20 **Δ 0,140** Ω

Full load torque **360,56** Nm  
 DOL Starting torque vs FL torque **1,94**  
 DOL Pull up torque vs FL torque **1,47**  
 DOL Pull out torque vs FL torque **3,09**  
 Star-Delta Starting torque vs FL torque **0,61**  
 Star-Delta Pull up torque vs FL torque **0,46**  
 Star-Delta Pull out torque vs FL torque **0,96**  
 DOL Starting current vs FL current **6,88**  
 Star Delta Starting current vs FL current **2,15**  
 Rotor Inertia **0,8070** kgm<sup>2</sup>

Bearing DE **6314 - ZZ C3**  
 Bearing NDE **6314 - ZZ C3**

WI	Change	date	sign.
<b>Dutchi Motors B.V.</b> P.O. Box 5390 NL-6802 EJ ARNHEM Tel : +31-(0)26 - 3541 600 Fax : +31-(0)26 - 3541 650		Discription Drawing made by :	date 27-04-04 sign. HVD
		<b>dutchi.motors@dutchi.nl</b> <b>www.dutchi.com</b>	

Power is our commodity, the world is our market !

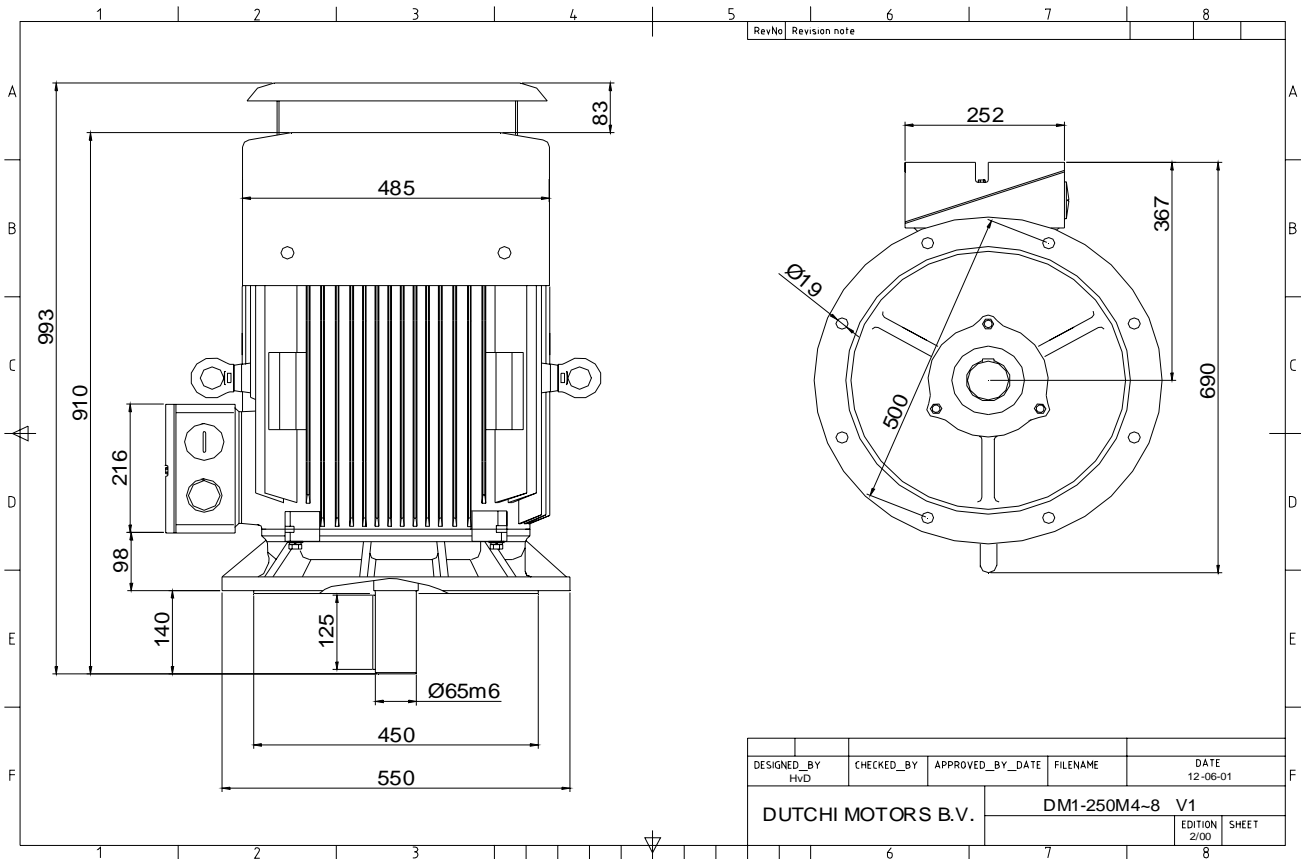

Specification **IEC 60034-1**  
 Manufacturer **Dutchi Motors B.V.**  
 Motor type **DM1- 250 M6**  
 Rated power **37** kW **S1** duty  
 Speed **980** r.p.m  
 Voltage **400** / **690** V  
 Frequency **50** Hz  
 Connection **Δ** / **Y**  
 Amps full load **66,0** / **38,1** A  
 Amps no-load(400V) **21,80** A  
 Enclosure **IP 55**  
 Insulation Class **F (temp. rise B (80 K))**

Max. coolant temp. **40°C**  
 Max. altitude **1.000** mtr, above sea level  
 Comment **3 x PTC 150°C**  
 Cable entries **2 x M63x1,5 + 1 x M20x1,5 (ptc)**

Feature **Cast-iron motor**  
 Weight **408** kg  
 Catalog no. **11036A37D**  
 Warranty **12~18 months**

Efficiency class **N/A**  
 Load data 100% 75% 50% 25%  
 Efficiency **91,6 91,7 90,7 85,8** %  
 Power factor **0,88 0,85 0,78 0,59**

Sound pressure level (1m) **63,9** dB(A)  
 Resistance R20 (open) **0,211** Ω  
 Resistance R20 **Δ 0,140** Ω

Full load torque **360,56** Nm  
 DOL Starting torque vs FL torque **1,94**  
 DOL Pull up torque vs FL torque **1,47**  
 DOL Pull out torque vs FL torque **3,09**  
 Star-Delta Starting torque vs FL torque **0,61**  
 Star-Delta Pull up torque vs FL torque **0,46**  
 Star-Delta Pull out torque vs FL torque **0,96**  
 DOL Starting current vs FL current **6,88**  
 Star Delta Starting current vs FL current **2,15**  
 Rotor Inertia **0,8070** kgm<sup>2</sup>

Bearing DE **6314 - ZZ C3**  
 Bearing NDE **6314 - ZZ C3**

WI	Change	date	sign.
Dutchi Motors B.V.		Description	date
P.O. Box 5390		Drawing made by :	27-04-04
NL-6802 EJ ARNHEM			
Tel : +31-(0)26 - 3541 600		dutchi.motors@dutchi.nl	
Fax : +31-(0)26 - 3541 650		www.dutchi.com	